

1 2 3 4 5 6 7 8 9 10 11 12

REV NO/版次	REVISION NOTE/修订注释	DATE/日期	SIGNATURE/签名

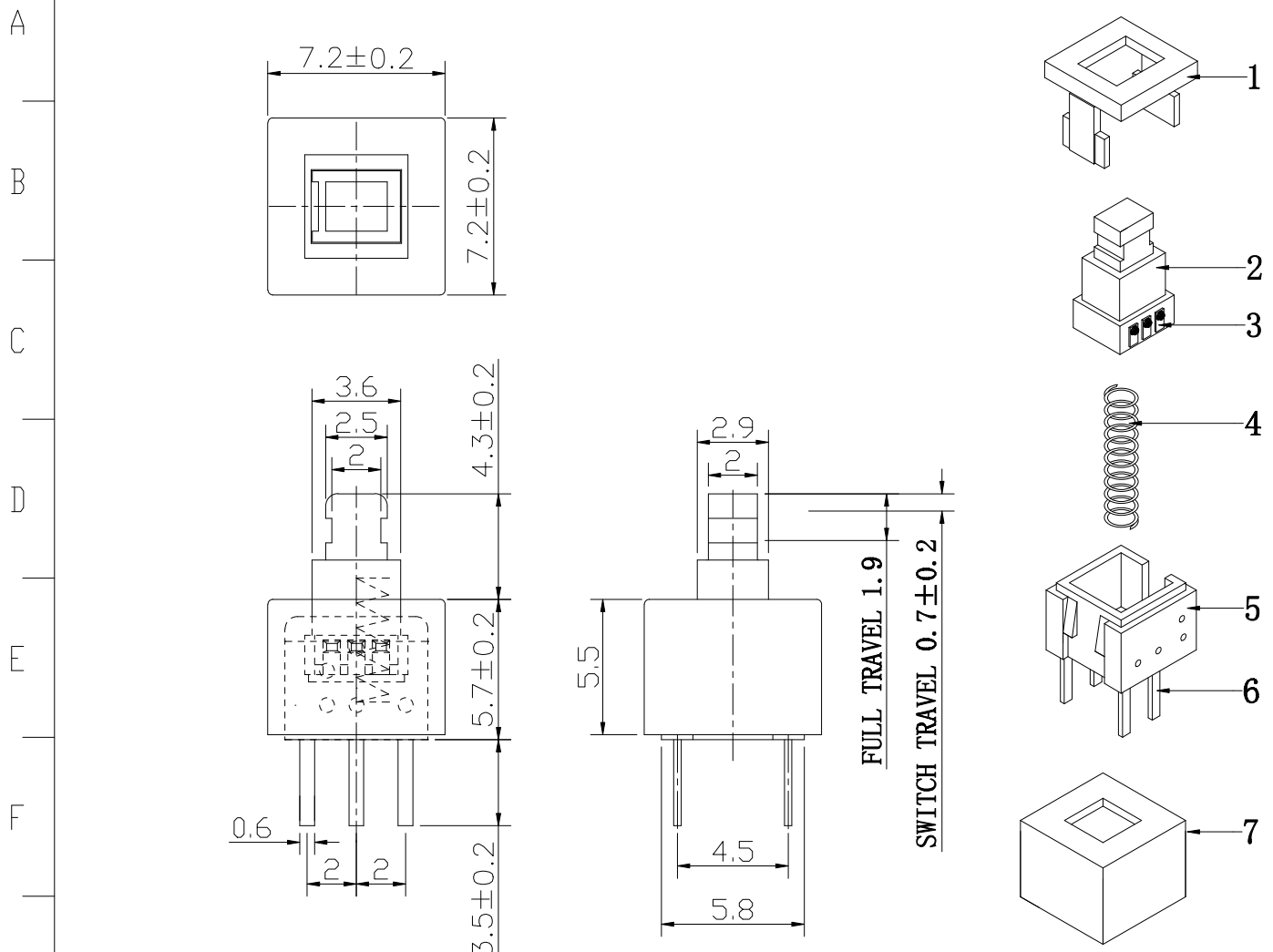

ELECTRICAL CHARACTERISTICS

- 1. RATING: DC 50V 0.5A
- 2. CONTACT RESISTANCE: 100mΩ MAX
- 3. INSULATION RESISTANCE: 100MΩ MIN
- 4. DIELECTRIC STRENGTH: AC 250V (50~60Hz)/60S

MECHANICAL CHARACTERISTICS

- 1. PRACTICAL TEMPERATURE RANG: -40℃~+85℃
- 2. OPERATING FORCE: 250±50gf
- 3. MECHANICAL LIFE: 20,000 cycles

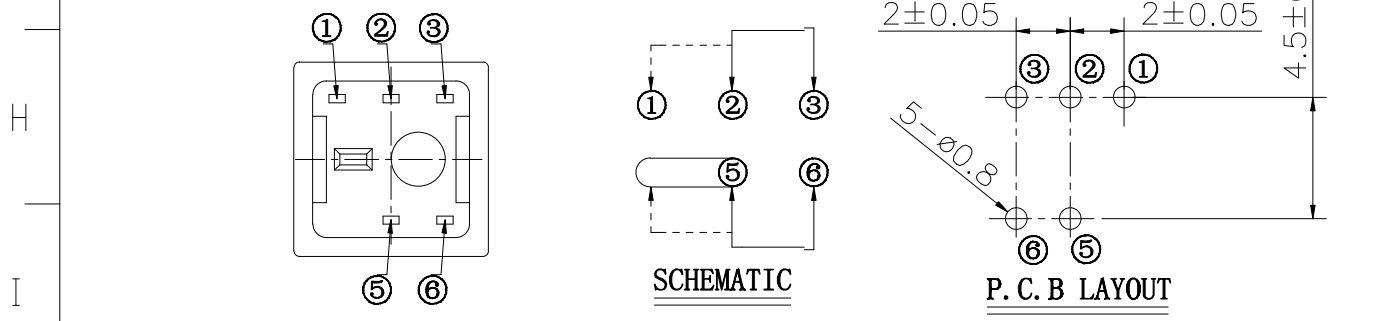

8				
7	SHELL	PA66	1	BLACK
6	TERMINAL	BRASS STRIP	6	Ag PLATED
5	CASE	PA66	1	BLACK
4	SPRING	SUS WIRE	1	NATURAL
3	CONTACT	BRONZE	2	Ag PLATED
2	KNOB	PBT	1	WHITE
1	COVER	PPA	1	BLACK
NO.	PART NAME	MATERIAL	QTY.	FINISHING

东莞市迪松电子科技有限公司

GENERAL TOLERANCE未指的公差		TITLE	
X. ± 0.5	X.° ± 5°	名称 PB-22E66-5P无锁	
.X ± 0.3	.X° ± 2°	PART NO. 零件编号	
.XX ± 0.2	.XX° ± 1°	DWG NO. 图纸编号	
.XXX ± 0.1	.XXX° ± 0.5°	PB-22E66	
APPROVAL 审批	CHECKED 核准	DRAWN 设计	UNIT 单位 (mm)
		WEIMIN SU	SCALE 比例
			1:1
			PROJ. 项目
			REV. 版本

1 2 3 4 5 6 7 8 9 10 11